

Modular Unit 10MB-300/900/1500

GENERAL DESCRIPTION

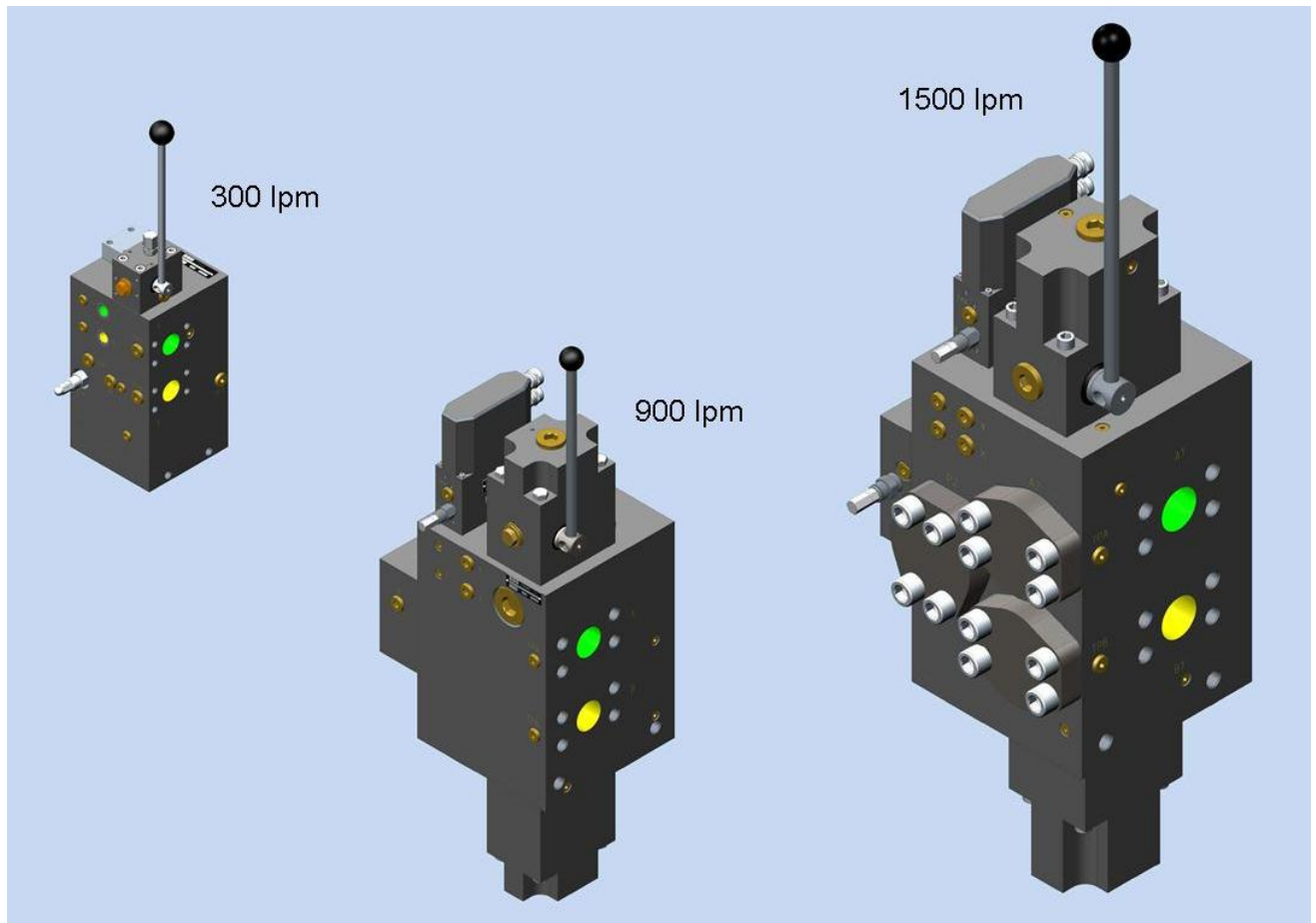

Figure 1 10MB-300/900/1500-1/37ER-2C General Arrangement

The Modular Units 10 MB is a complete unit for proportional control of hydraulic driven winches and has the following improved characteristics:

- Extremely compact design.
- Designed to withstand marine surroundings
- Pressure compensated flow control system, which gives excellent metering.
- Hand lever with 39° control movement in each direction.
- Wide ranges of options.
- Different capacity range.

For more details about types and options, please refer to section 'MODULAR CODE'.

Modular Unit 10MB-300/900/1500

MODULAR CODE

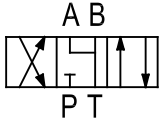
Options	Remarks	Design Code	Fill in
<i>Standard</i>			
- Directional Control Valve		10MB	
- Pressure compensator flow control			
- Max operating pressure 250bar/ 300	350bar/900-1500		
<i>Size</i>			
Rated flow Q = 300 l/min	Pressure $\Delta p = 6,5$ bar	300	
Rated flow Q = 900 l/min	Pressure $\Delta p = 17$ bar	900	
Rated flow Q = 1200 l/min	Pressure $\Delta p = 4$ bar	1200	
Rated flow Q = 1500 l/min	Pressure $\Delta p = 7$ bar	1500	
<i>Directional Control Valve 4/3</i>			
Manually operated		1	
Manual/remote operated		37	
Manually operated with brake release 4BA3		1B	
Manually/remote operated with brake release 4BA3		37B	
Proportionally electrical remote controlled	Includes separate R	37E	
Proportionally electrical remote controlled	With integrated R	37ER	
Proportionally electrical remote controlled, with brake release 4BA3	Includes separate R for Proportional valve (item E)	37BE	
Proportionally electrical remote controlled, with brake release 4BA3	With integrated R	37BER	
<i>Spool type</i>			
	No option	2C	

Modular Unit 10MB-300/900/1500

Options	Remarks	Design Code	Fill in
<i>Two-speed valve</i>			
Manually operated		T	
Manually operated with reduced pressure		TR	
Hydraulic operated		TH	
Hydraulic operated with reduced pressure		THR	
Manually/Hydraulic operated with reduced pressure		TMHR	
Electric operated		TE	
Electric operated with reduced pressure		TER	
Pressure reducing valve only		R	
<i>Lever placement</i>			
Standard mounting		No code	
Standard mounting, lever inside cover		.1X	
Cover 90° right, lever standard		.7E	
Cover 90° right, lever inside		.7E1X	
<i>Modification</i>			
Code		(001-999)	

In example a 10MB intend for flow 300 l/min, remote operated, will have modular code:
10MB-300-37-2C

Modular Unit 10MB-300/900/1500

VALVE DESCRIPTION 10MB-300-900, HYDRAULIC SCHEMATIC

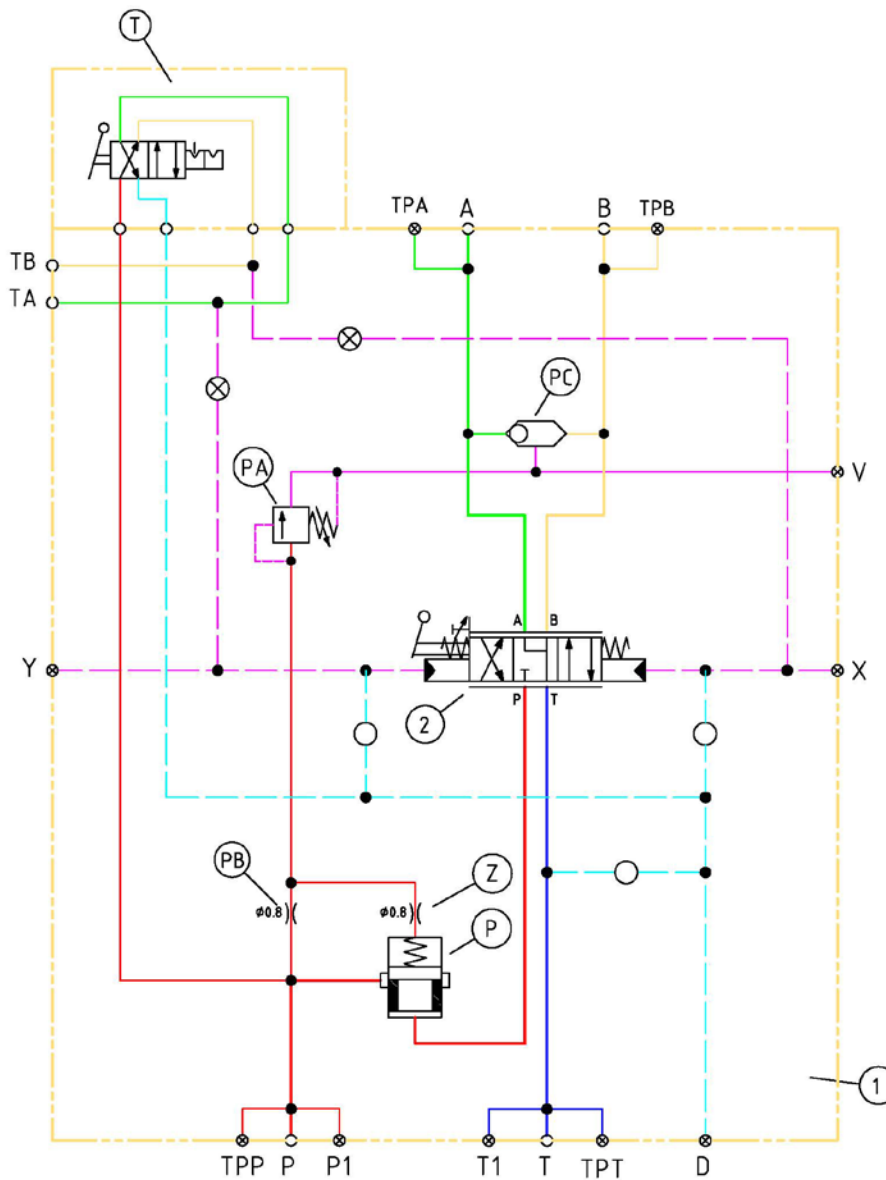

Figure 2a 10MB-300-900 Hydraulic Schematic (with valve for 2-speed or clutch/brake).

Modular Unit 10MB-300/900/1500

TECHNICAL VALVE DESCRIPTION 10MB

Item 1 **Main block.**

Item 2 **Directional control valve 4/3.**

This is a three positions directional spool valve with hand lever. When activating the directional valve handle, the operator controls the direction and drive speed of the drum. Throttling grooves in the main spool open progressively for flow either to A or B port. The spool has adjustable end stoppers in both end covers for limiting of the spool stroke. A shorter travel of the spool will result in an increase of the pressure drop through the spool and an increase of maximum flow through the valve.

Option code 37:

Directional valve is prepared to be hydraulically proportional remote controlled.

Pilot pressure 5-20 bar.

Generally about the pressure compensator system.

This is a load independent system, which means that a fixed spool stroke on the directional valve will give equal flow independent of the load at the motor/drum.

The main directional spool (2) in conjunction with pressure compensator flow control system (P, PA, PB, PC and Z), regulates proportional oil flow to either A (Heave rotation) or B (Lower rotation) by sensing the pressure either in A or B line through the shuttle valve (PC). When operating directional valve (2), the spool will open progressively to A or B. Pressure compensation element will maintain equal Δp across the directional valve. Maximum flow over the main directional valve is depending on the force induced on the pressure compensator element (P). This force is made up of a spring force in the compensator element item (P), and an adjustable spring force in the compensator pilot valve (PA) and the load pressure sensing in A or B via (PC). When setting is altered on the compensator pilot valve (PA), the flow will change.

When adjusting pressure relief valve PA, the Δp through the directional valve will alter, and thus maximum flow to the hydraulic motor.

Item P **Pressure compensator element. (working with PA, PB, Z, PC)**

Normally opens the modulating element, which acts as a pressure compensator to maintain a constant pressure drop across the directional valve (together with PC, PB, PA and Z).

Item Z **Adjustable throttling.**

Adjustable throttle for the pressure compensator element, if the element is fluctuating.

Item PB **Nozzle**

Maintains flow to compensator pilot valve PA.

Item PA **Compensator pilot valve.**

The spring on the compensator is rather weak. Therefore, pressure created by an adjustable pressure relief valve is added to the spring force.

Modular Unit 10MB-300/900/1500

Item PC Shuttle valve for the pressure compensator.
Port V can be used for load sensing or in some applications for a hydraulically operated brake release valve.

OPTIONS- DESCRIPTION 10MB

Code 37 Manually/remote operated.
1B Manually operated, with brake release 4BA3
37B Manually/remote operated, with brake release 4BA3.
 Ports dimension for brake release valve 4BA3: $\frac{3}{8}$ " BSPP

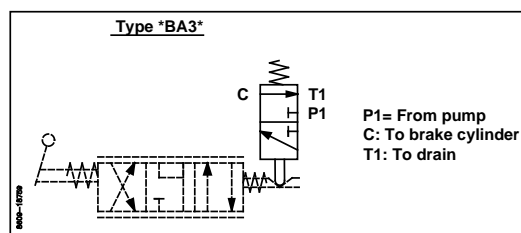

Code 37E Manually/Proportionally electrical remote operated.
 Proportional reducing valve item E is Hydranor 8FGB4131021-11/11.
 Pressure reducing valve not integrated in 8FGB4131021-11/11, but separate sandwich component.

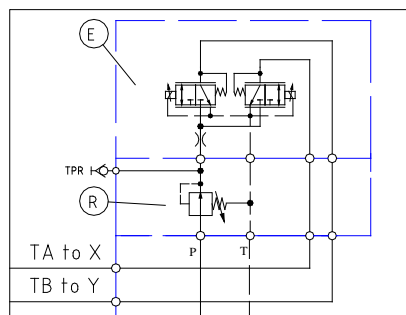

Code 37ER Manually/Proportionally electrical remote operated with integrated pressure reducing valve and external drain port D. T from ER to main block is plugged.

Proportional reducing valve item ER is Hydranor 8FGBR4431021-11/11-D

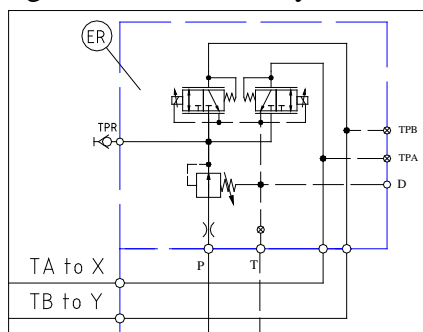

Modular Unit 10MB-300/900/1500

Two-speed valve module

This is a 4/2 directional valve for selecting the speed when using two-speed motor.

- Code T** Manually operated 4/2-direction valve.
TR Manually operated 4/2-direction valve with reduced pressure.
TH Hydraulic operated 4/2-direction valve.
THR Hydraulic operated 4/2-direction valve with reduced pressure.
TMHR Manually/Hydraulic operated 4/2-direction valve with reduced pressure.
TE Electric (solenoid) operated 4/2-direction valve.
TER Electric (solenoid) operated 4/2-direction valve with reduced pressure.
R Pressure reducing valve only, e.g. for external functions. The reduced pressure is led to port TA.
 Pressure reducing valve is in some cases to be used together with brake release valve for reduced pressure to the brake.

Port connection two-speed system:
 TA/TB: $\frac{3}{8}$ " BSPP

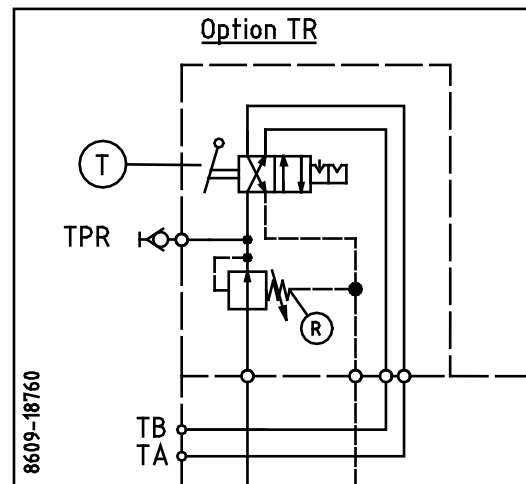

Modular Unit 10MB-300/900/1500

DIMENSIONS 10MB-900

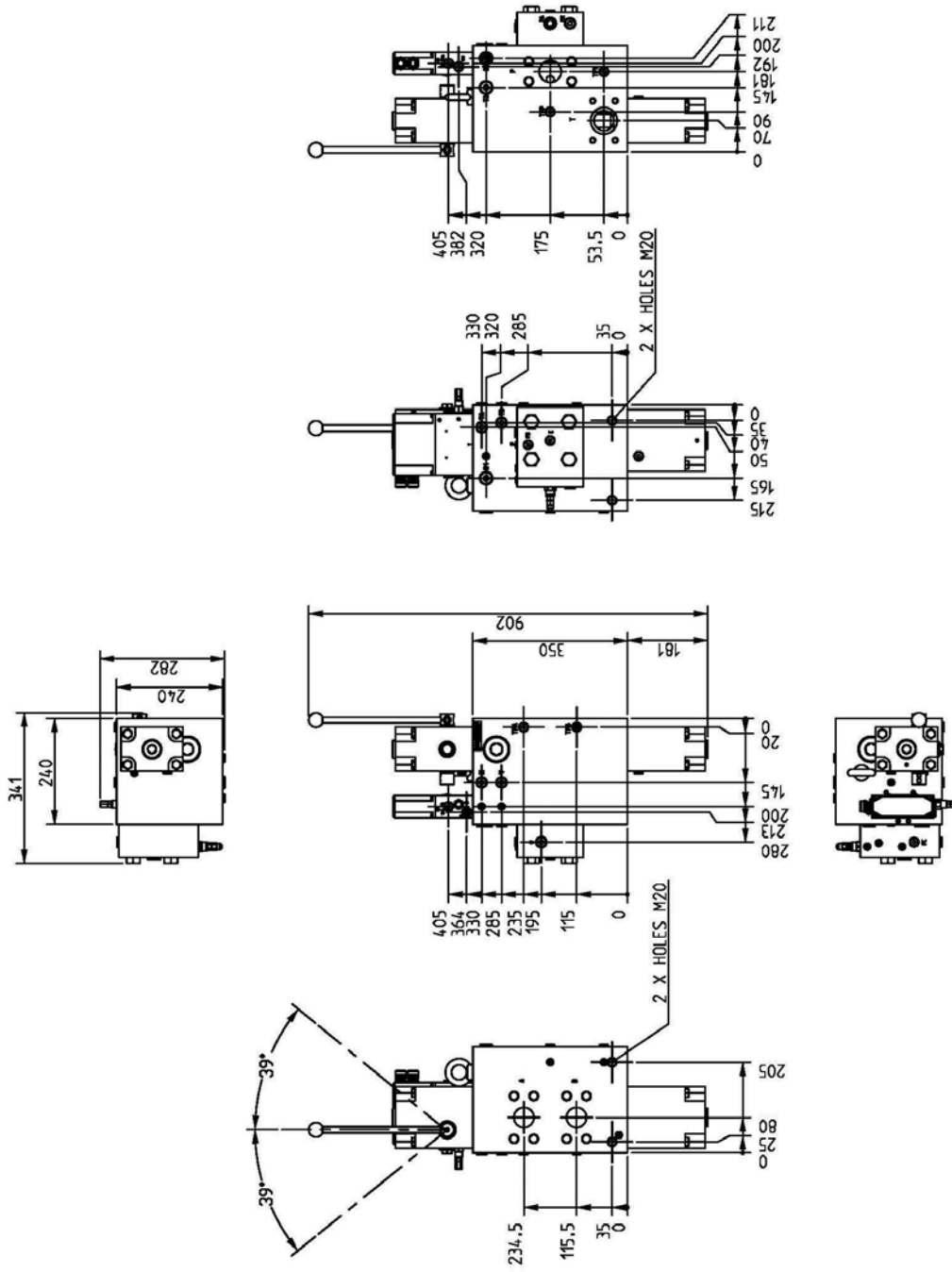

Figure 4b Dimensions 10MB-900

Modular Unit 10MB-300/900/1500

DIMENSIONS 10MB-1200/1500

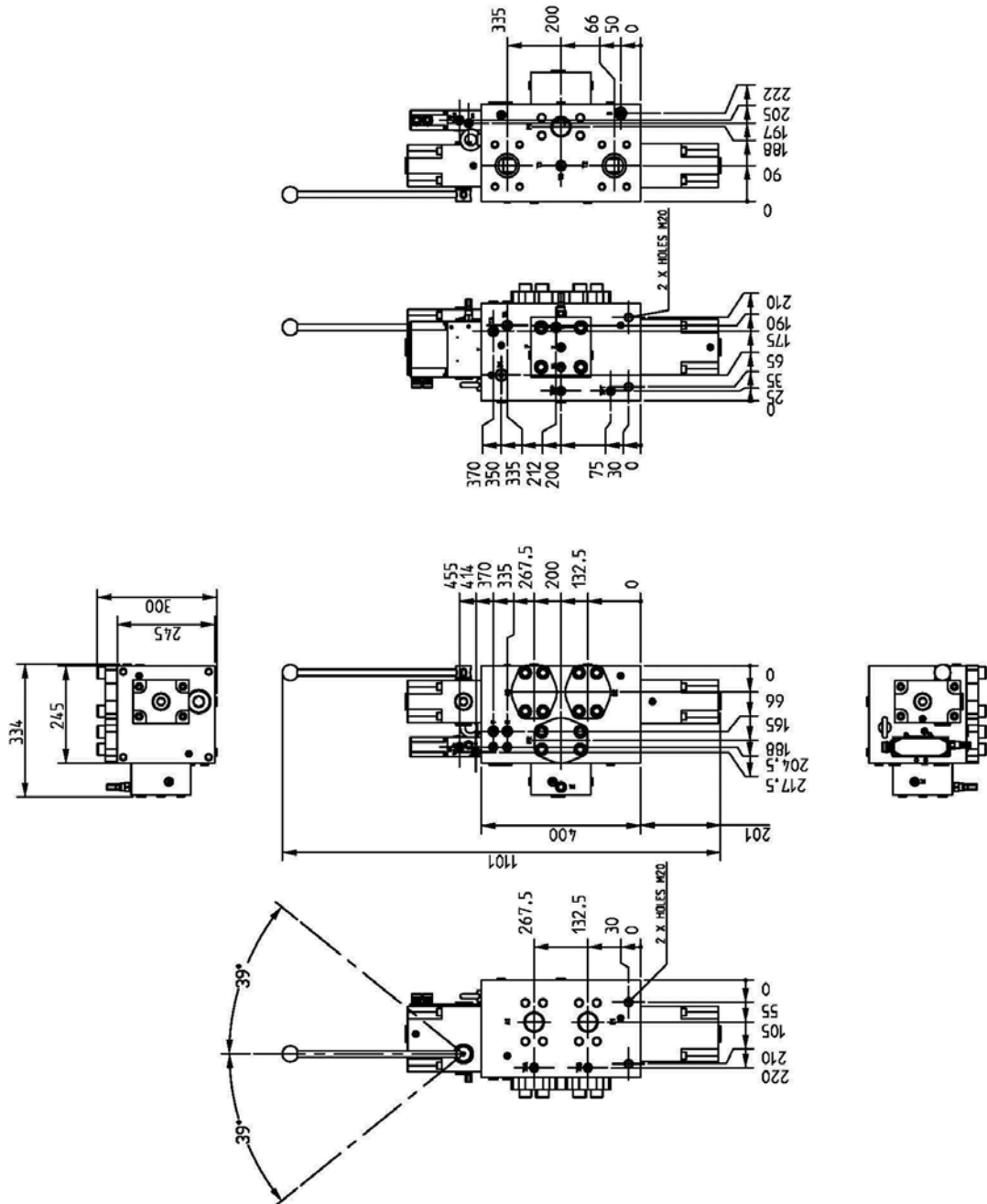

Figure 4c Dimensions 10MB-1200/1500

Modular Unit 10MB-300/900/1500

PRESSURE DROP 10MB

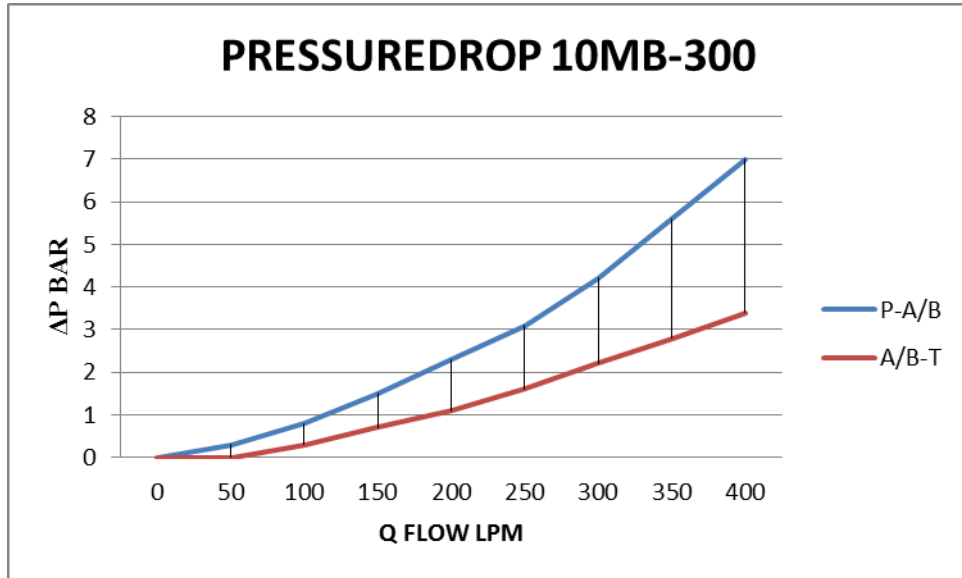

Figure 5a Pressure drop 10MB-300

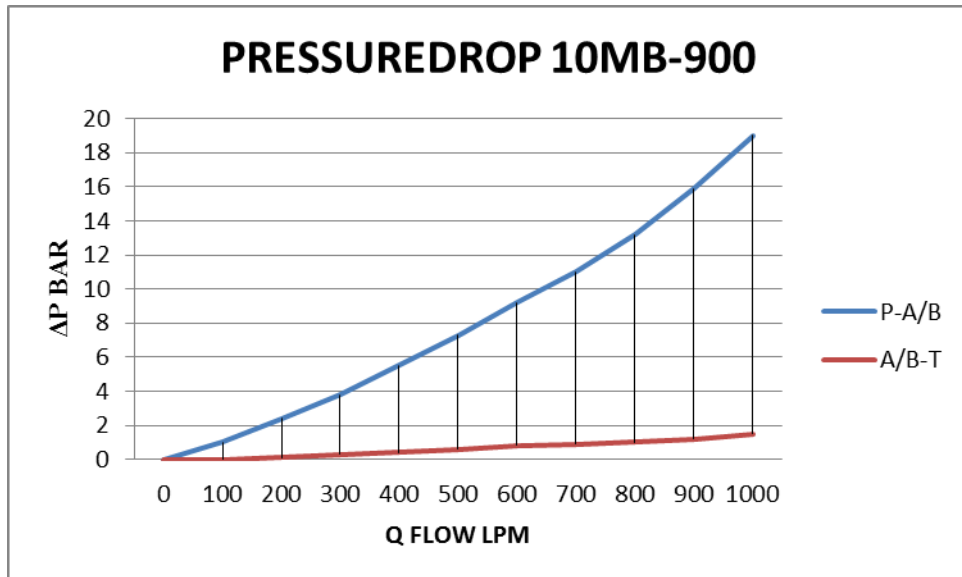
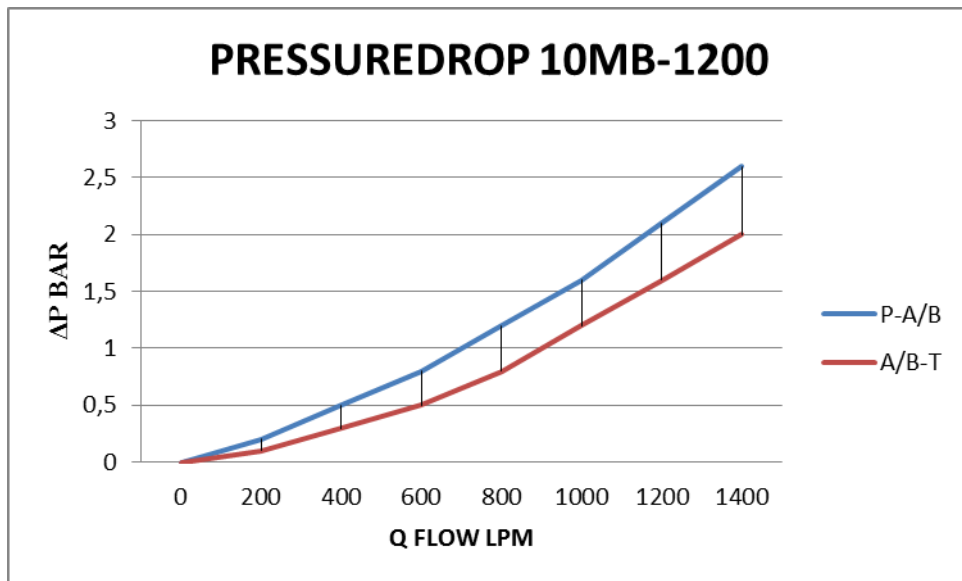
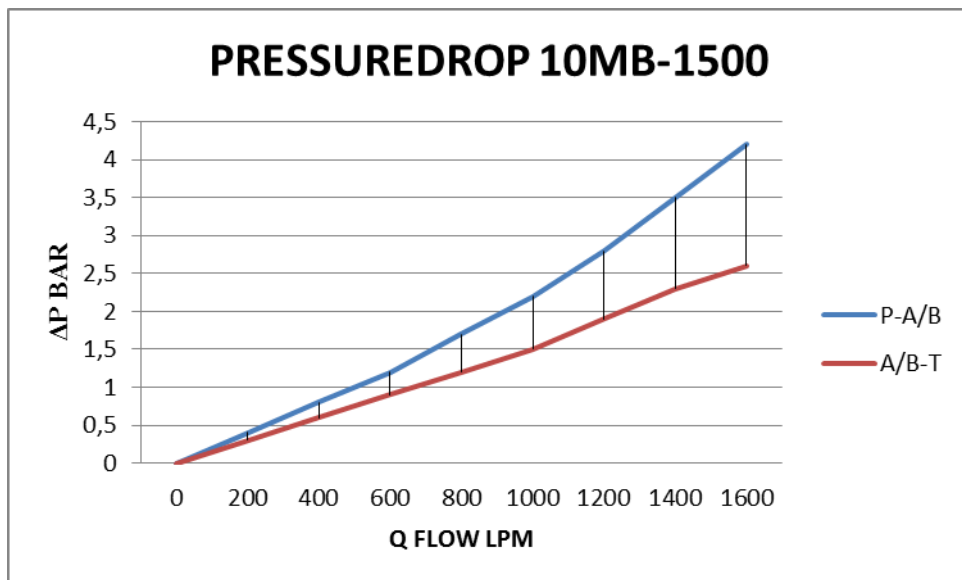

Figure 5b Pressure drop 10MB-900

Modular Unit 10MB-300/900/1500

*Figure 5c Pressure drop 10MB-1200**Figure 5d Pressure drop 10MB-1500*

Modular Unit 10MB-300/900/1500

TECHNICAL DATA

Description	Symbol	Unit	Value		
Flow (Δp 32 bar)	Q_{max}	l/min	10MB-300	10MB-900	10MB-1200/1500
Flow area		l/min	250-320	850-1000	1100-1550
Max. operating pressure in ports P, A and B	P_{max}	bar	300/250 900-1500/350		
Recommended max. pressure in port T. (See Note 1.)	T_{max}	bar	20		
Directional valve pilot pressure	P	bar	5-20		
Weight basic version	m	kg	10MB-300/900	6MB-1200/1500	
			27/185	455	
Hydraulic fluid			Mineral oils for hydraulic system		
Viscosity range:	ν	m ² /s	10 to 350 (cST)		
Viscosity index:	VI		> 120		
Filtration, recommended filter with $\beta_{20} \geq 100$			Class 9 according to NAS 1638, 18/15 according to ISO 4406		
Fluid temperature range:	T		-20°C to + 70°C		
Ambient temperature range	T		-20°C to + 50°C		
Standard Body Material			EN-GJS-400-15 (GGG 40)		
Standard O-rings			Nitrile shore 70		

Note1: Be aware that pressure on the tank port T is direct additive to valve setting for pressure relief valve item D, and pressure reducing valve item R (If selected option R). Pressure peaks in T port can influence on the stability of the system, particular proportional remote control of main directional valve.

Modular Unit 10MB-300/900/1500

Interfaces:

Connections			
Ports	Dimensions 100MB-300	Dimensions 100MB-900	Dimensions 100MB-1200/1500
P, A and B	1 ¼" SAE 3000	2" SAE 6000	2 x 2" SAE 6000
T	1 ¼" SAE 3000	2 ½" SAE 3000	2 x 3" SAE 3000
V, X, Y, TA, TB	⅜" BSPP	⅜" BSPP	⅜" BSPP
DRAIN	½" BSPP	½" BSPP	2 x ½" BSPP
TPP, TPT, TPA and TPB	¼" BSPP	¼" BSPP	¼" BSPP
Mounting Screws:	4 x M12	4 x M16	4 x M20

Modular Unit 10MB-300/900/1500

INSTALLATION

The Modular unit 10MB is installed with 4 screws to a bracket. Please refer to 'Interfaces' in section 'TECHNICAL DATA', for details about screws and o-rings.

OPERATION

Manual control is performed by the hand lever. The valve is delivered with a centring spring, which means that main spool will return to the neutral position after operating the hand lever.

Option 37 (Manual/remote operated):

The directional valve is prepared to be hydraulically proportional remote controlled. An external pilot pressure moves the spool to the requested position Pilot pressure 5-20 bar. The valves are equipped with a hand lever for overriding the pilot pressure.

MAINTENANCE

Check the valve for proper function. Visually check the valve and if required, paint unpainted (damaged) areas.

CAUTION: Do not paint the hand levers shaft seals.

SPARE PART

Seal Kit Set is available.

STORAGE

If storage longer than 6 months is expected, the valve must be kept in a dry room, free from dust and protected against sudden large temperature variations. For storage longer than 12 months, the valve must be filled with inhibition oil. Before use check all visible seals and flush with clean oil.

MARKING

Inlets and outlets are marked, refer to figure in section 'GENERAL DESCRIPTION'.