

MODULAR WINCH UNITS

8MB for flow 40-200 lpm

Winch control manifolds for variable pumps

- Pipe mounted model
- Compact design
- Pressure compensator system for load independent control of hydraulic motor
- Load control valve of spool design
- Actuations
 - Manual
 - Hydraulic remote
 - Proportional electric operation
 - Combination of those above
- Options for
 - Brake release valve
 - Remote operated pressure relief A - T/B for tension control
 - Two speed selector valve
 - Up to 2 NG6 flanges for operation of external functions
 - Prepared to be fitted directly on hydraulic motor by use of an intermediate adapter plate

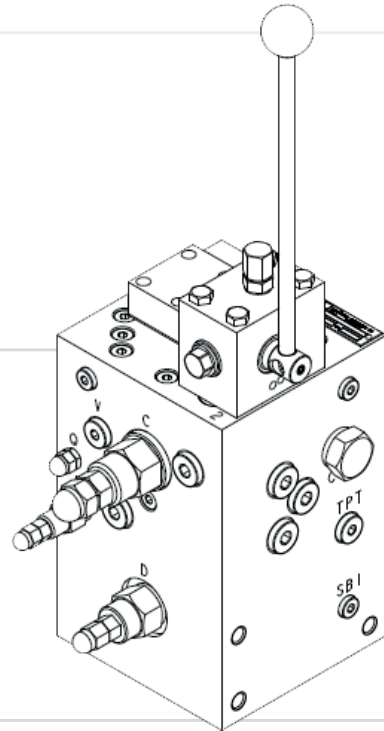

DESCRIPTION	DATA	
Flow ranges	70	40-70 l/min
	140	70-140 l/min
	200	140-200 l/min
Weight	70/140/200	32 kg
Max pressure	P, A, B	350 bar
	T	20 bar
Pilot pressure		5-20 bar
Test pressure		420 bar
Fluid temperature range		-20°C to +70°C
Ambient temperature range		-20°C to +50°C

